

3.4 BUILDING CONSTRUCTION (446)

The 2012 KCSE examinations for Building Construction consisted of two papers namely Paper 1 (theory) and Paper 2 (Practical Project). The theory was worth 60% while practical was worth 40% of the final mark. The revised syllabus was tested for the first time but the format and weighting of the two papers was the same as in the previous years.

Candidates General Performance

Table 11: *Candidates' overall performance for the period 2008 to 2012*

Year	Paper	Candidature	Maximum Score	Mean Score	Standard Deviation
2008	1		60	33.83	5.36
	2		40	15.78	2.47
	Overall	18	100	49.61	5.98
2009	1		60	31.13	6.96
	2		40	18.77	4.57
	Overall	195	100	49.74	9.38
2010	1		60	26.26	9.09
	2		40	17.53	3.38
	Overall	225	100	43.79	13.32
2011	1		60	23.72	9.09
	2		40	15.76	4.32
	Overall	301	100	37.70	12.58
2012	1		60	25.27	9.79
	2		40	16.90	4.86
	Overall	376	100	42.13	13.64

From the above table, the following observations can be made.

- (i) The mean score improved from 37.70 for the year 2011 to 42.13 for the year 2012.
- (ii) The candidature increased from 301 in the year 2011 to 376 in the year 2012.
- (iii) The candidature has been increasing since the year 2008.

3.4.1 Building Construction paper 1 (446/1)

The questions which were reported to have been poorly performed have been analyzed with a view to pointing out candidates' weaknesses and propose suggestions on some remedial measures that would be taken in order to improve performance in future. The questions for discussions include 1 (b), 4, 9.

Question 1 (b)

Sketch and label a plain concrete roofing tile.
Candidates were tested in sketching skills.

Weaknesses

Most candidates could not sketch and label the concrete roofing tile correctly. Some showed the position for nailing which should not be the case in tiles.

Advice to Teachers

They should cover the whole syllabus and when it comes to tiles the method of securing should be emphasized.

Expected Responses

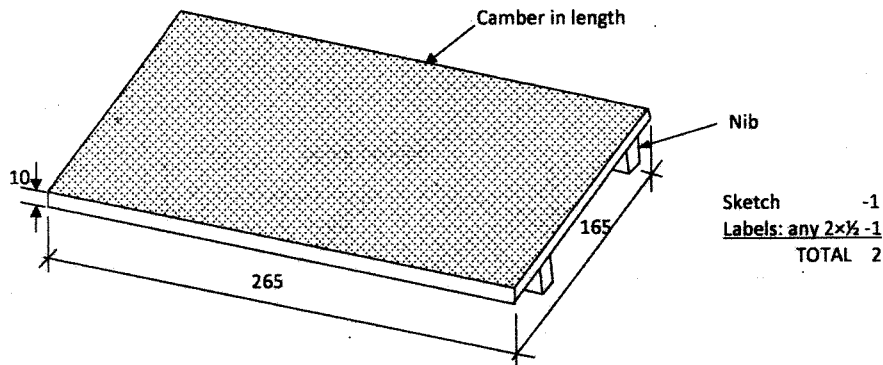

Question 4

- (a) State the recommended minimum height above the finished floor level for the following electrical fittings:
- Switch
 - Wall socket

Candidates were tested on electrical fittings as per a finished floor.

Weaknesses

None of the candidates was able to give the correct height for the switch and wall socket.

Advice to Teachers

They need to explain to the students the use of IEEE Regulations as applied to electrical fittings in buildings

Expected Responses

- Switch-1400 mm
- Wall socket- 325mm

Question 9 (b)

Sketch the following lengthening joints:

- (i) Plain scarf joint
- (ii) Splay joint

Candidates were expected to sketch the given lengthening joints.

Weaknesses

Most candidates could not differentiate between scarf and splay joints.

Advice to Teachers

They should cover the topic on timber joints thoroughly.

Expected Responses

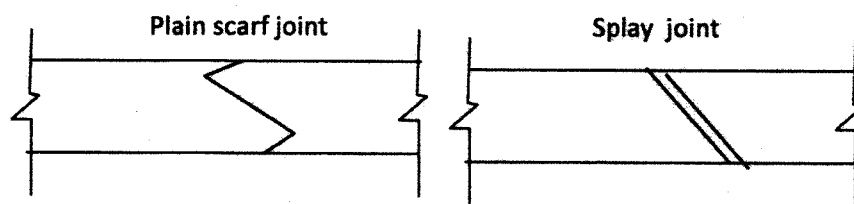

3.18.2 Building Construction Paper 2 (446/2)

As in the previous years, the council designed a suitable project for this level together with a comprehensive marking scheme. The subject teachers used the working drawings to supervise the construction and the marking scheme to mark the candidates' projects. The marks were then sent to the council through the D.E.O's offices.

4.4 BUILDING CONSTRUCTION (446)



MANYAM FRANCHISE
Discover! Learn! Apply!

4.4.1 Building Construction Paper 1 (446/1)

SECTION A (40 marks)

Answer all the questions in this section in the spaces provided.

- 1 (a) Differentiate between a flat roof and a pitched roof. (2 marks)
- (b) Sketch and label a plain concrete roofing tile. (2 marks)
- 2 (a) State **two** reasons why the current traditional houses are better than caves of the past. (1 mark)
- (b) Distinguish between a turning piece and a centre piece as used in arches. (3 marks)
- 3 (a) State **one** function of each of the following fixings:
- (i) cornice; (1 mark)
- (ii) dado rail. (1 mark)
- (b) State **four** places where a vertical damp proof course may be placed in a building. (2 marks)
- 4 (a) State the recommended minimum height above the finished floor level for the following electrical fittings:
- (i) switch; (1 mark)
- (ii) wall socket outlet. (1 mark)
- (b) State **two** advantages of each of the following paint finishes:
- (i) matt; (1 mark)
- (ii) gloss paint. (1 mark)
- 5 State **four**:
- (a) advantages of timber scaffolds over steel scaffolds. (2 marks)
- (b) activities that must be carried out immediately a contractor takes possession of a site. (2 marks)
- 6 Outline the procedure of constructing a foot path finished with precast concrete slabs. (4 marks)
- 7 (a) Using line diagrams, sketch the following types of profile boards:
- (i) intermediate profile; (1 mark)
- (ii) corner profile. (1 mark)

(b) State **two** properties of each of the following materials for making mortar:

(i) sand; (1 mark)

(ii) water. (1 mark)

8 Sketch and label a vertical cross section of a trench to show the method of establishing a uniform depth using a boning rod. (4 marks)

9 (a) State **two** factors to consider when selecting a building site. (1 mark)

(b) Sketch the following lengthening joints:

(i) plain scarf joint; (1½ marks)

(ii) splay joint. (1½ marks)

10 **Figure 1** shows a shaped block drawn in isometric.

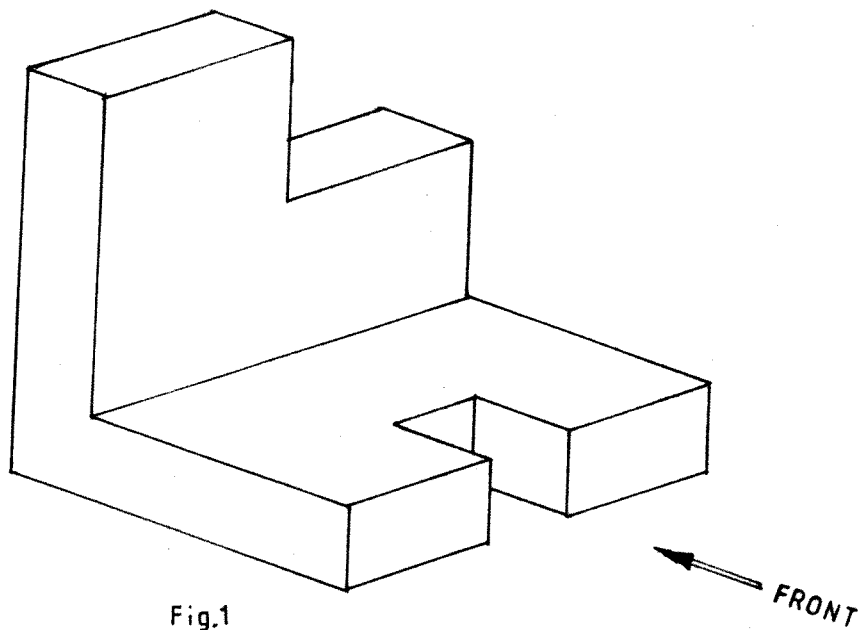

Fig.1

Figure 1

In 3rd angle projection, sketch the **three** views of the block. (4 marks)

SECTION B (60 marks)

Answer **question 11** on the A3 paper provided and any other **three** questions from this section in the spaces provided after question 15.

Candidates are advised **not** to spend more than **25 minutes** on question 11.

11 Figure 2 shows a pictorial view of a stand.

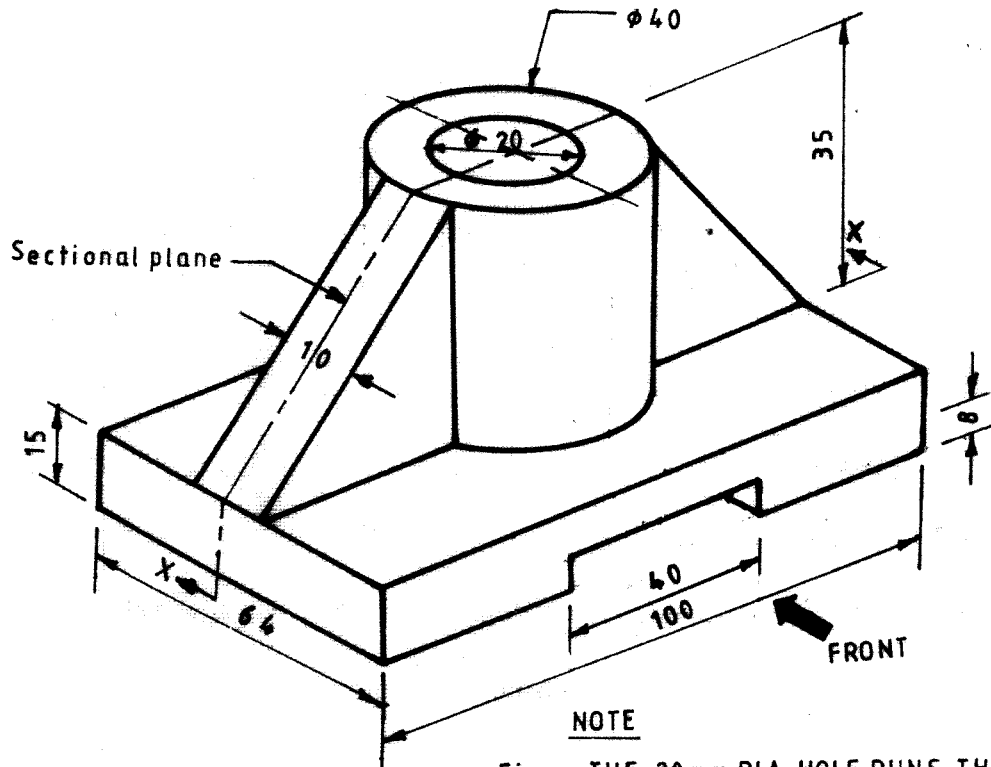

Figure 2

NOTE
 •THE 20 mm DIA. HOLE RUNS THROUGH TO THE BOTTOM
 •THE GROOVE AT THE BASE RUNS ACROSS

To a scale of 1:1, draw the following in first angle projection:

(15 marks)

- (i) sectional front elevation along X - X;
- (ii) end elevation;
- (iii) plan.

Insert **four** major dimensions.

- 12** (a) A foundation wall is 150 mm thick. With the aid of a labelled sketch, determine the:
- (i) depth of foundation concrete;
 - (ii) projection of the foundation concrete;

- (iii) foundation width. (6 marks)
- (b) (i) Differentiate between a common rafter and a jack rafter. (2 marks)
- (ii) Sketch and label a collar roof showing the mandatory height of the collar. (7 marks)
- 13** (a) State **three** factors to consider when transporting concrete on site. (3 marks)
- (b) Explain the following terminologies as used in foundations:
- (i) bearing capacity; (2 marks)
- (ii) made ground. (2 marks)
- (c) Explain the following activities carried out before laying foundations:
- (i) levelling the bottom; (2 marks)
- (ii) consolidation of the bottom; (2 marks)
- (iii) pegging; (2 marks)
- (iv) wetting. (2 marks)
- 14** (a) Outline the procedure of applying a rough cast finish on a new wall. (7 marks)
- (b) Using labelled sketches explain **two** methods of fixing a timber door frame to a masonry wall. (8 marks)
- 15** Sketch and label a direct cold water supply system for a one storey building. (15 marks)

4.4.2 Building Construction Paper 2 (446/2)

TEST A: BLOCKWORK AND BRICKWORK (54 marks) (13 Hours)

Test A shows a plan, incomplete elevation and a section of a return angle wall with an opening, plasterwork screed and a skirting. One length of the wall is built in blockwork showing some courses of brickwork while the other length of wall is built in brickwork showing at quoins. Part of the inner surface of the wall, at the return angle is plastered. The floor is wood float screeded and a 100 mm skirting applied. Blockwork joints are finished flush while the archwork joints and all brickwork joints are tooled.

MATERIAL SPECIFICATION PER CANDIDATE

No.	ITEM DESCRIPTION	MATERIAL	QUANTITY	SIZE (mm)	REMARKS
1	Blockwork	Concrete blocks	16	450 x 225 x 150	Bedded in Sand/ Lime mortar
2	Brickwork	Clay/ concrete bricks	52	225 x 115 x 75	Bedded in 10 mm Sand/ Lime plaster
3	Mortar	Lime/ sand	Sufficient	-	For bedding blocks/ bricks and plaster
4	Archwork	Timber	1 piece	1000 x 250 x20	Arch support
5	Archwork	Timber	1 piece	1000 x 38 x20	To be used as gauge and straight edge

BLOCKWORK AND BRICKWORK

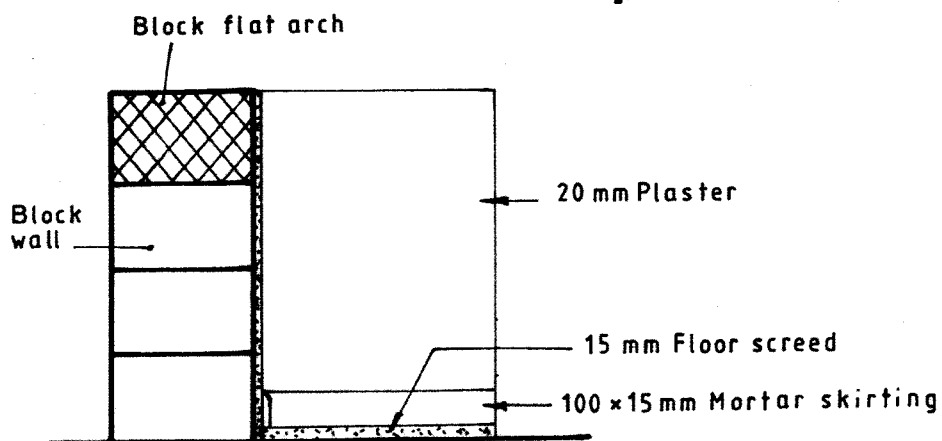
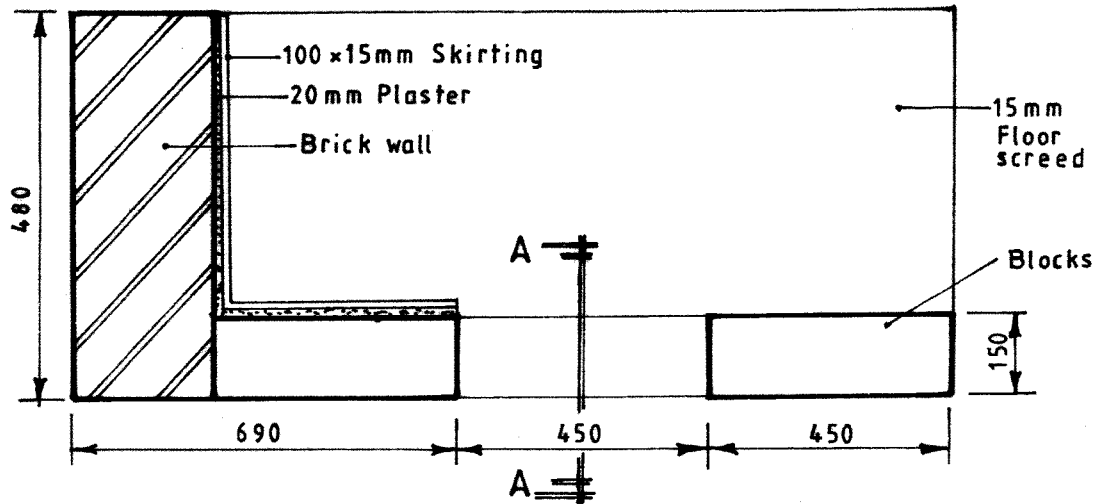
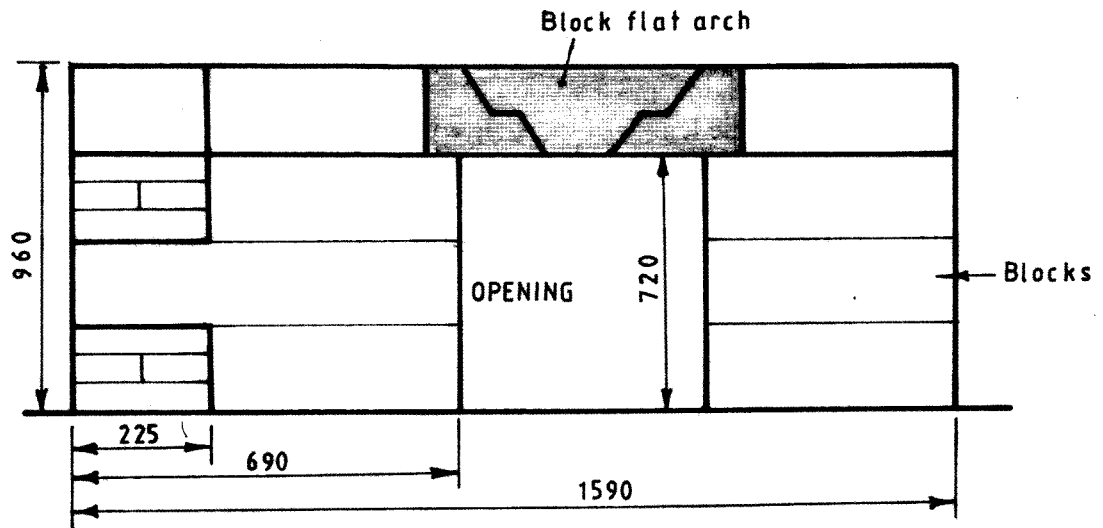

SECTION A-A

TEST B: FORMWORK (46 marks)
(12 Hours)

Test B shows a pictorial view and elevations part of a formwork for an in-situ concrete floorslab and edge beam. Prepare the timber pieces and construct the model.

MATERIALS SPECIFICATIONS PER CANDIDATE

(a) **CUTTING LIST**

ITEM No.	DESCRIPTION	SIZE	No. OFF	REMARKS
1	Cross head	650 x 45 x 45	2	
2	Joist	230 x 45 x 20	2	
3	Runner	600 x 45 x 20	1	
4	Strut	1200 x 45 x 20	1	Cut into 4 pieces
5	Stiffener	600 x 45 x 20	1	Cut into 2 pieces
6	Cleat	600 x 45 x 20	1	Cut into 8 pieces
7	Bottom and Sides	600 x 150 x 20	4	
8	Plywood	350 x 150 x 3	1	

- (b) **NAILS-** 38 mm wire nails - Sufficient
- 25 mm wire nails - Sufficient

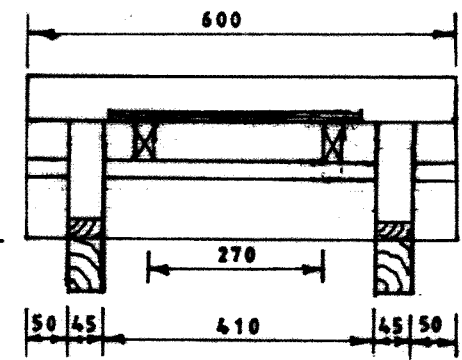
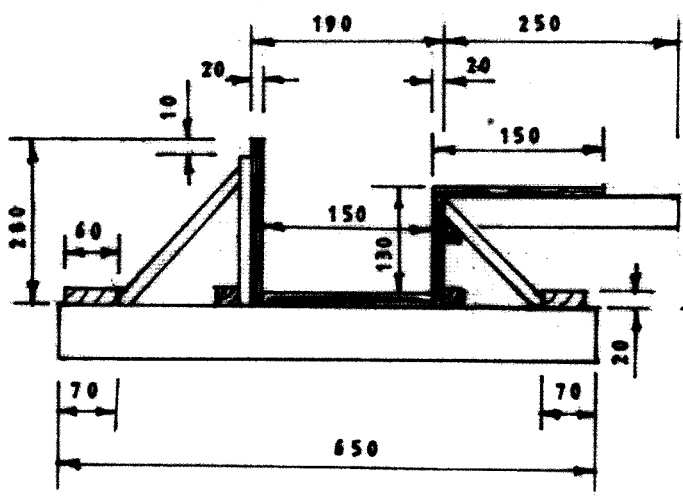
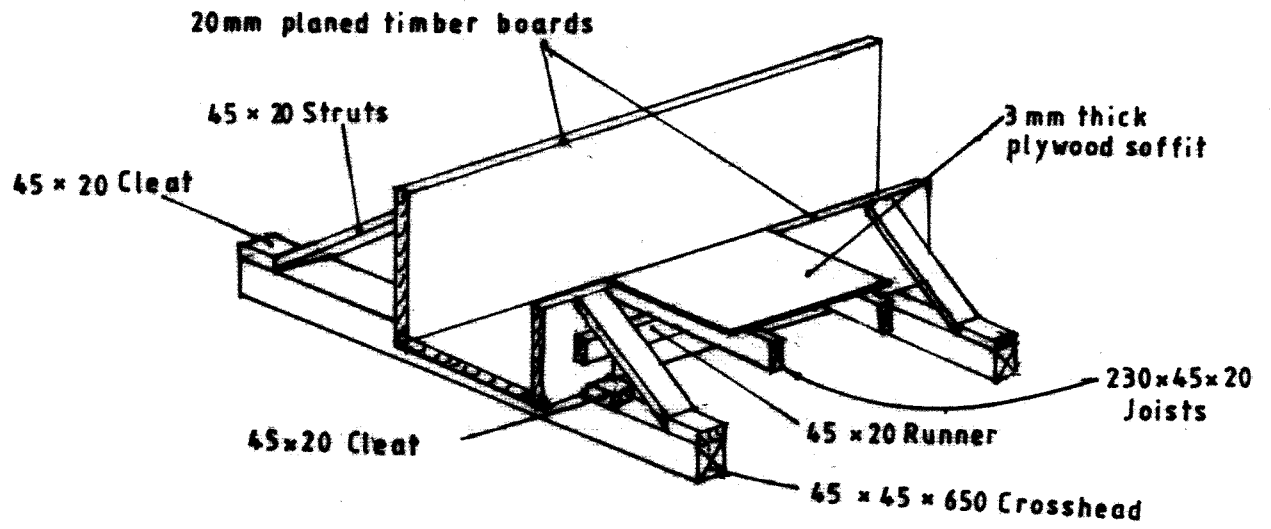

5.4 BUILDING CONSTRUCTION (446)



MANYAM FRANCHISE
Discover! Learn! Apply

5.4.1 Building Construction Paper 1 (446/1)

1 (a) To differentiate between a **flat roof** and a **pitched roof**:

- A flat roof with a pitch 10° or less than 10° to the horizontal base.

(1 mark)

- Pitched roof refers to any roof whose angle of slope to the horizontal lies between 10° and 70° .

(1 mark)

Plain concrete Roofing Tile

(b)

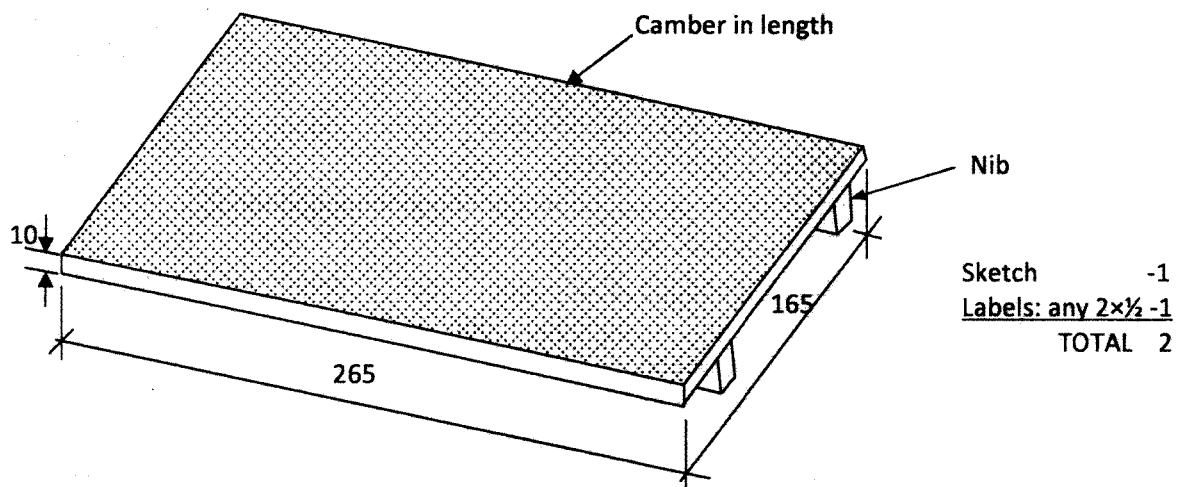

2. (a) **Two** reasons why the current **traditional houses** are better than caves.

- better living conditions.
- caves had no option of design.
- caves are not found everywhere.

Any 2 x $1\Box = 1$ mark

(b) To distinguish between a turning piece and a centre piece.

(i) Turning piece:

Is a small timber or metal support for holding the weight of the arch during construction.

It is a member used to support arches during construction to a distance not more than one metre in span, hence used for light arch work construction. It has no laggings.

($1\Box$ marks)

(ii) Centre piece:

Is also a temporary support. Holds larger units in wider or longer spans. It has ribs with laggings spanning across the ribs for provision of strength. It is larger/bigger than the Turning piece.

(Accept sketches)

($1\Box$ marks)

3. (a) **One function of:**

Cornice - Timber mouldings used to cover the junction between the wall and the ceiling.

Dado rail - Horizontal timber mouldings fixed in a position to prevent the walls from being damaged by the back of chairs.

2 x 1 = 2 marks

(b) **Four places where a vertical d.p.c. may be placed are:**

- (i) Reveals of door and window openings.
- (ii) Retaining walls.
- (iii) Basement walls.
- (iv) Parapet walls.
- (v) Boot lintels in openings.

Any 4 x = 2 marks

4. (a) **Recommended minimum heights above finished floor level:**

- Switch 1400mm
- Wall socket outlet 325mm

2 x 1 = 2 marks

(b) **Advantages of using matt paint finish.**

- Avoid reflection of light sources.
- Do minimise surface irregularities if any.

2 x 1 = 1 mark

Advantages of using gloss paint finish.

- Provides maximum washability.
- Are durable

(2 x) = 1 mark)

5. (a) **Advantages of timber scaffolds over steel scaffold.**

- In areas where timber is available, it is cheap and easy to obtain.
- No fittings required.
- No extra maintenance costs.
- Easily cut to size.
- Wastes and old components can be sold as fire wood and make some money.

Any 4 x 1 = 2 marks

(b) **Four** activities that must be carried out immediately a contractor takes possession of a site.

- Fencing the site.
- Clearing the site.
- Setting out the building.
- Establishing a datum level.
- Constructing site huts

Any 4 x \square = 2 marks

6. Procedure of constructing a footpath pavement finished with a precast concrete slab.

- Remove the top soil.
- Fill it up with granular material
- Compact the surface fully to the required gradient
- Lay the pre-cast concrete slab

4 marks

7. (a) Sketches to show:

Intermediate profile

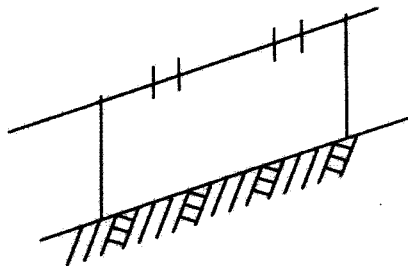

Intermediate profile

(1 Mark)

Corner profile

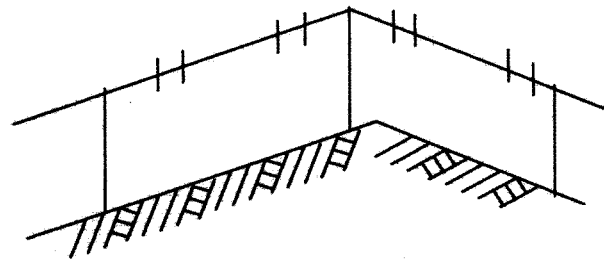

Corner profile

(1 Mark)

(b) Properties of:

Sand

- Free from too much clay
- Well graded
- Free from organic impurities

Any 2 x \square = 1 mark

Water

- Free from impurities
- Free from sulphates
- Clean/palatable

Any 2 x \square = 1 mark

8. Method of establishing uniform depth of a trench bottom using a bonning rod.

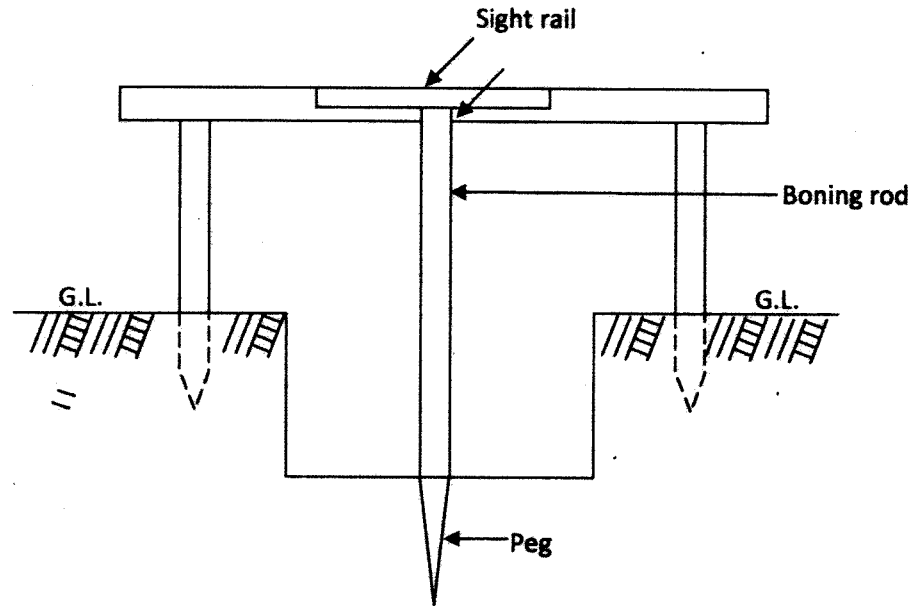

Sketch 2 marks
 Labels 4 x □ = 2 mark
 4 marks

9. (a) Factors considered when selecting site.

- Availability of services
- Orientation of site
- Ease of communication
- Site conditions

Any 2 x □ = 1 mark

(b) Plain scarf joint

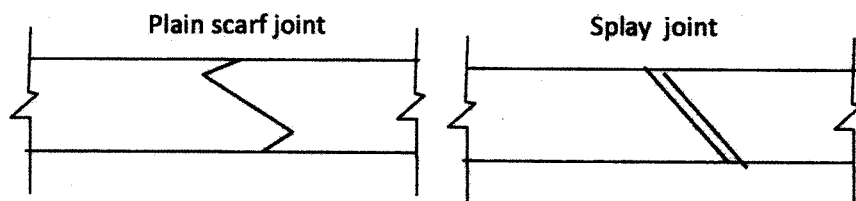

Sketch 1 mark
 Naming 1□ mark
 2 x 1□ = 3 marks

10.

Interpretation 3 Angle = 1 Mark
 Plan = 1 Mark
 Front elevation = 1 Mark
 End elevation = 1 Mark
= 4 Marks

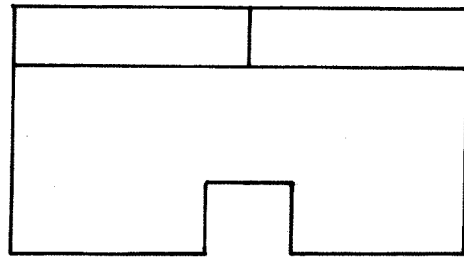

PLAN

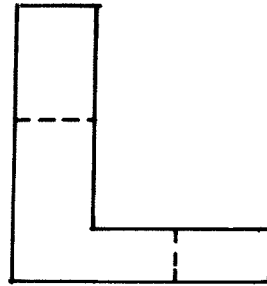

EE

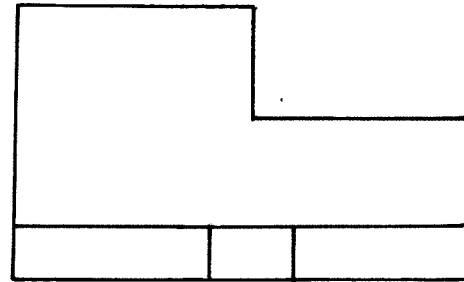

FE

11.

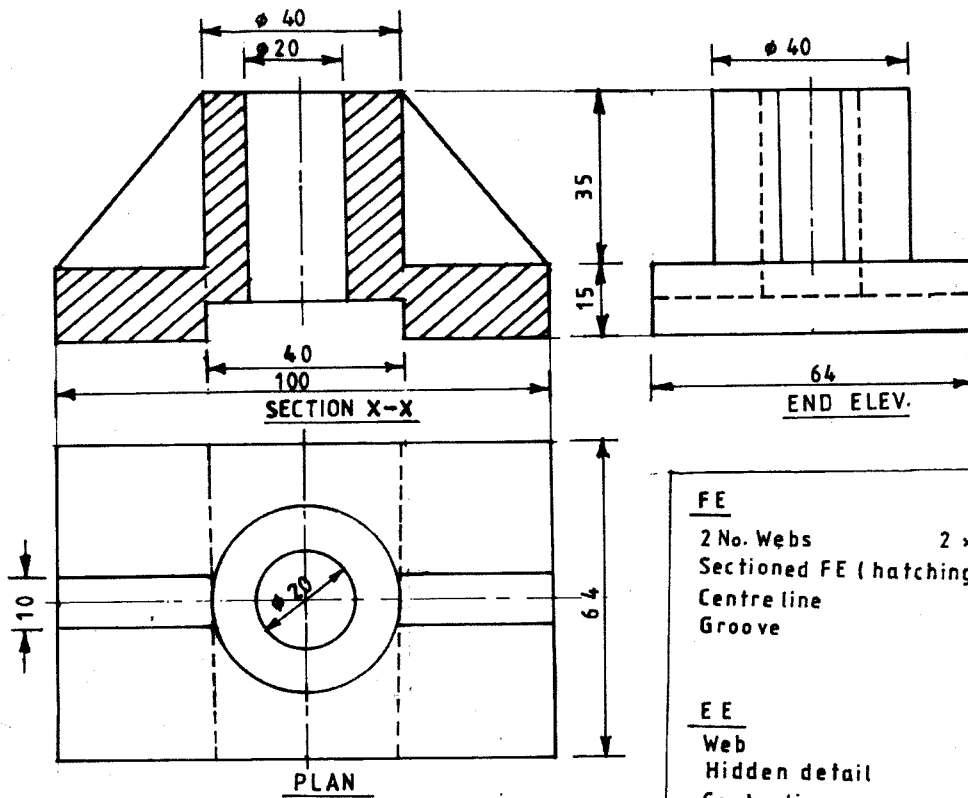

<u>FE</u>	
2 No. Webs	$2 \times \frac{1}{2} = 1$
Sectioned FE (hatching)	= 2
Centre line	= 1
Groove	= 1
	<u>5</u>
<u>EE</u>	
Web	= 1
Hidden detail	= 2
Centre line	= 1
	<u>4</u>
<u>PLAN</u>	
Circles $\phi 40$ & $\phi 20$	= 2
Webs 2 No	$2 \times \frac{1}{2} = 1$
Centre lines	= 1
Hidden detail	= 2
	<u>6</u>

12. Foundation dimensions

- (a) Wall thickness $W = d = \frac{1}{3}$ spread (s)
 $\therefore W = 150 \text{ mm} = d = 150 \text{ mm}$
 If $150 \text{ mm} = \frac{1}{3}S$

mark
 mark
 mark

Then $S = \frac{150}{1} \times \frac{3}{1} = 450 \text{ mm}$

mark

2 marks

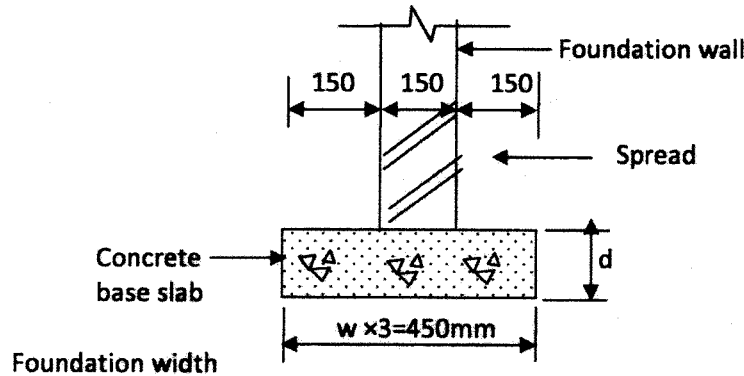

Sketch = 3 marks
 Labels any 2 x = 1 mark
 4 marks
 Total = 6 marks

- (b) (i) Differentiate between a **common rafter** and a **jack rafter**.

- Common rafters are the main load bearing members of a roof, they span between the wall plate at eaves level up to the ridge.

1 mark

- Jack rafters are also load bearing rafters but span from ridge to valley rafter or from hip rafter to wall plate.

1 mark

- (ii) To sketch and label a collar roof.

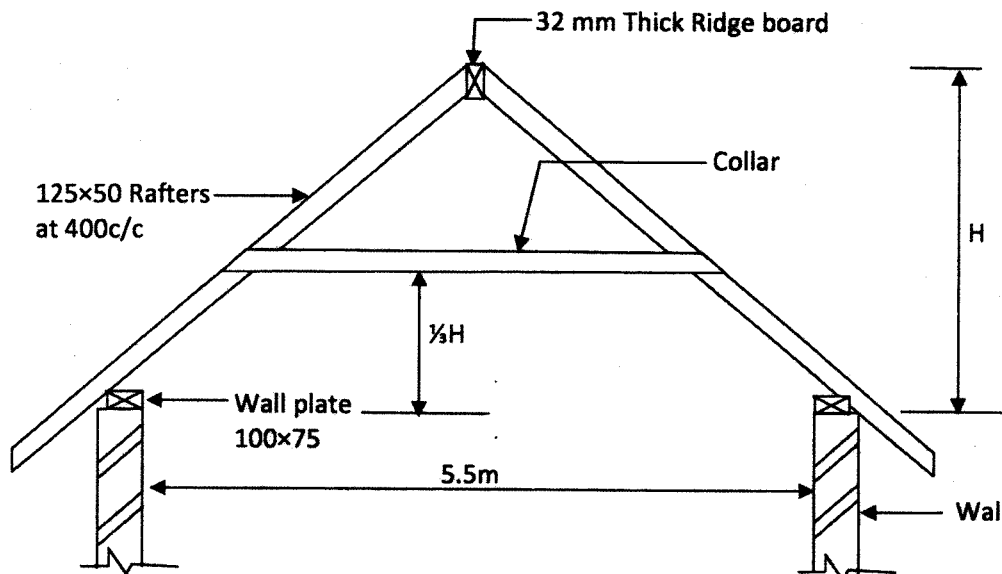

Sketch - 4 marks
 labels any 4 x = 2 marks
 Mandatory requirements = 1 mark
 7 marks

13. (a) Factors to consider when transporting concrete on site:

- distance should be kept to minimum to avoid setting
- container should be watertight
- transport on smooth surface to avoid segregation
- container should be covered when it is raining

Any 3 x 1 = 3 marks

(b) Terminologies used in foundations

Bearing capacity

- This is the safe load per unit area which the ground can carry.

Made ground

- Is refuse, excavated rock or soil deposited for the purpose of filling in a depression or for raising the site above its material level.

2 x 2 = 4 marks

(c) Activities carried out before laying foundations

Levelling the bottom

This is a process of forming levels or ensuring that the bottom of the trench is level. It starts from the lowest point along a run of the trench. Pegs are driven into the bottom and levels taken from peg to peg to ensure they are all level. Raised parts are cut while the low parts are filled.

Consolidation of the bottom

The bottom of the trench is raised or compacted to ensure a solid base. This may reveal pockets in the base which are filled and compacted level with the bottom.

Pegging

Pegs are driven into the bottom of the trench at predetermined distances. These pegs are used in conjunction with the spirit level to ensure a given level for pouring concrete. Concrete is levelled off to the top of the pegs.

Wetting

This is the last preparation done to the bottom of the trench before concrete is poured. Water is sprayed or sprinkled to the bottom of the trench just a few minutes before concreting starts.

4 x 2 = 8 marks

14. (a) Procedure of applying a rough cast finish on a new wall.

- remove any sticking mortar on the wall surface
- clean the mortar joints and remove any protruding mortar on the joints
- fill any holes that may exist along on the wall joint either vertical or horizontal
- sprinkle water on the surface of the wall
- apply the first coat of mortar which should be liquidish using a hard machine sprayer
- apply a second coat with a more thicker coat all over the wall surface
- finish with a third lighter coat to ensure uniform final finish

7 marks

(b) Two methods of fixing a timber door frame to a masonry wall.

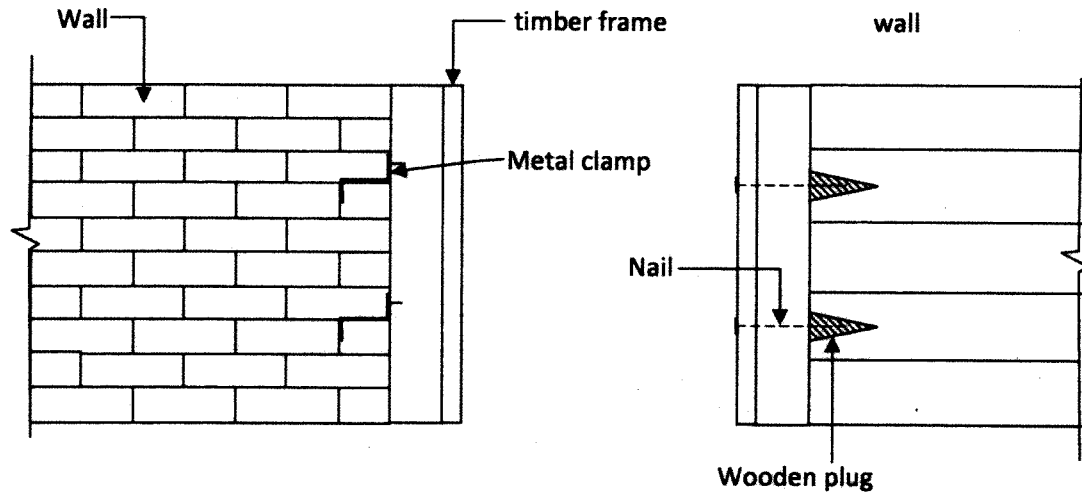

- A metal clamp with a fish tail end is fixed to the back of the frame using wood screws
- A recess/hole is cut in the wall to accommodate the metal clamp and then covered with concrete.
- A hole/recess is cut into the masonry wall to accommodate a wooden plug.
- The plug is driven flush to the wall.
- The frame is nailed to the plug.

Sketches 2 x 2 = 4 marks
labels any 2 x \square x 2 = 2 marks
Explanation 1 x 2 = 2 marks
8 marks

15. Direct cold water supply system

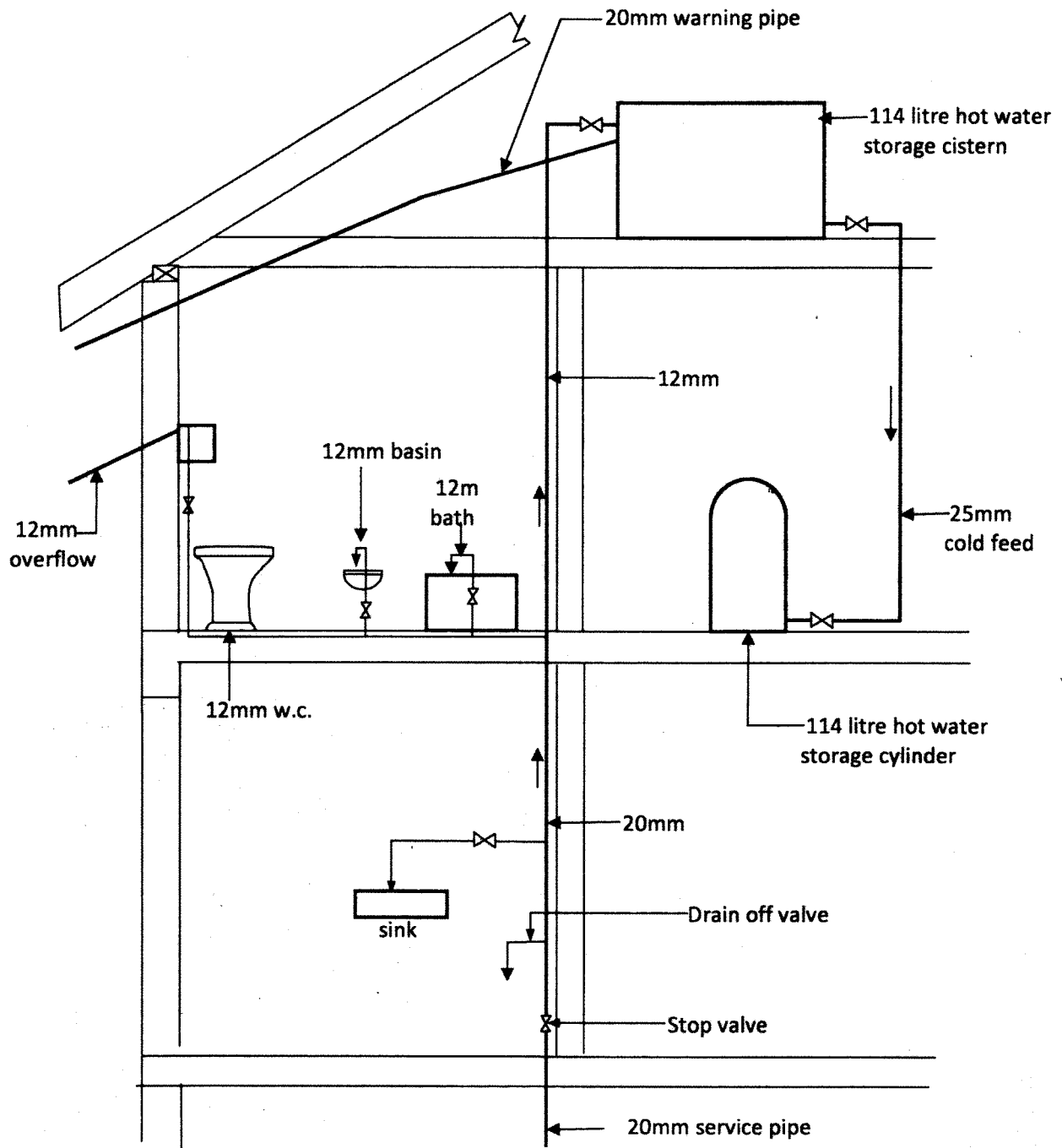

Sketch = 6 marks
 labels any 10 x □ = 5 marks
 Fittings in position any 6 x □ = 3 marks
 Direction of flow any 2 x ½ = 1 mark
 15 marks