

3.2 WOOD WORK (444)

The 2014 KCSE examination for wood work consisted of two papers namely Paper 1 (theory) and Paper 2 (Practical Project). The theory was worth 60% while practical was worth 40% of the final mark. Both papers followed the usual setting format as those of the previous years.

Candidates General Performance

Table 10: *Candidates Overall Performance for the period 2009 up to 2014*

Year	Paper	Candidature	Maximum Score	Mean Score	Standard Deviation
2009	1		60	28.27	10.30
	2		40	18.84	6.07
	Overall	424	100	47.12	15.49
2010	1		60	30.18	8.31
	2		40	20.18	4.55
	Overall	375	100	50.01	12.27
2011	1		60	21.24	9.46
	2		40	14.28	5.18
	Overall	447	100	35.49	13.93
2012	1		60	27.66	9.81
	2	393	40	18.42	5.14
	Overall		100	46.01	14.13
2013	1		60	31.97	9.81
	2	322	40	21.42	5.43
	Overall		100	53.32	14.40
2014	1		60	26.54	8.62
	2	331	40	17.74	4.17
	Overall		100	44.25	13.93

From the above table, the following observations can be made:

- (i) The mean score dropped from 53.32 in the year 2013 to 44.25 in the year 2014.
- (ii) The standard deviation also dropped from 9.81 in the year 2013 to 8.62 in the year 2014.
- (iii) The candidature increased from 322 in the year 2013 to 331 in the year 2014.

3.2.1 Woodwork Paper 1 (444/1)

The questions which were reported to have been poorly responded to have been analyzed with a view to pointing out candidates' weaknesses and propose suggestions on some remedial measures that need to be taken in order to improve performance in future. The questions for discussions include 7, 9, 10 and 11.

Question 7

State **four** safety precautions to be observed when using a lathe machine. (4 marks)

Weaknesses

Most candidates did not seem to know what a lathe machine is

Advice to Teachers

Visit workshops/training institutes with lathe machines.

Acquire and use text books with lathe machines.

Cover the entire syllabus.

Expected response

- Select the correct speed for the work to be turned.
- Ensure the work is secured to the face plate or between centres.
- Spin work by hand to ensure that it clears the lathe bed and tool rest.
- Always return tools to the tray - do not place them on the bed of the lathe.
- Wear protective clothing.

Question 9

Give **two** disadvantages of oil-based paint.

(2 marks)

Weaknesses

Most candidates lacked knowledge on oil paints

Advice to Teachers

Visit paint manufacturers and sales outlets

Cover the topic on finishes (paints)

Expected response

- They are flammable.
- Produces an odour when newly applied.
- Requires a thinner therefore more expensive.

Question 10

Figure 3 shows a mitred bridle joint.

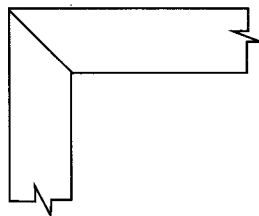

Figure 3

Sketch an exploded pictorial view of the joint.

(5 marks)

Weaknesses

Some candidates seemed not to know the mitred bridle joint

Advice to Teachers

Cover joints in woodwork adequately and insist on correct and proportional sketches
Candidates should know the difference between the following types of sketches:

- Pictorial sketches
- Orthographic sketches
- Exploded views

Expected response

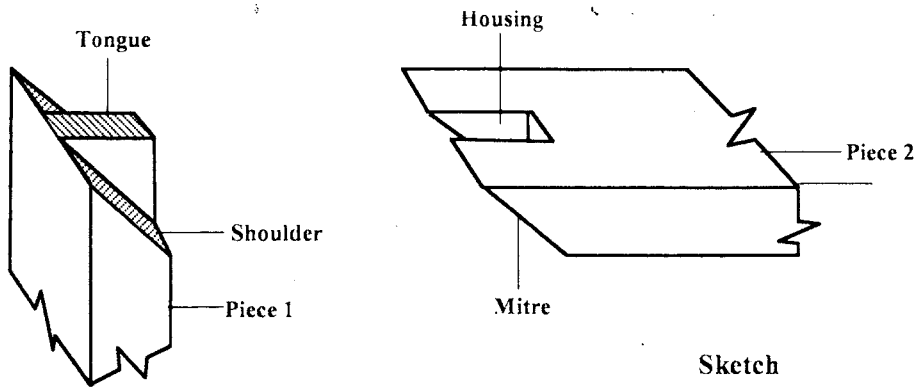

Mitred Bridle Joint

Sketch =3

Labels (any $4 \times \frac{1}{2}$) =2

5 marks

Question 11

Figure 4 shows a shaped block drawn in isometric projection.

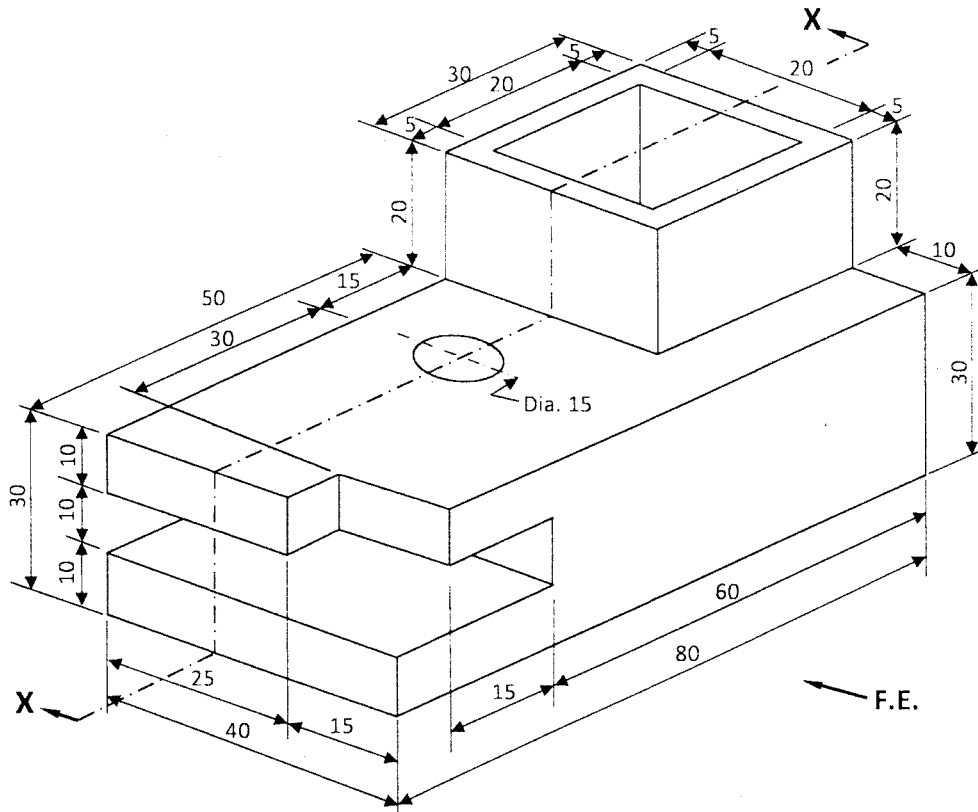

Figure 4

Draw, full size, the following views in first angle projection:

- a sectional front elevation of the cutting plane x-x;
- a plan;
- indicate six dimensions.

(15 marks)

Weaknesses

Most candidates could not draw the sectional view while others could not draw the hidden details and centre line on the drawing.

Advice to Teacher

Cover the topic on orthographic projections adequately
Give exercises on uses of various types of lines

Expected response:

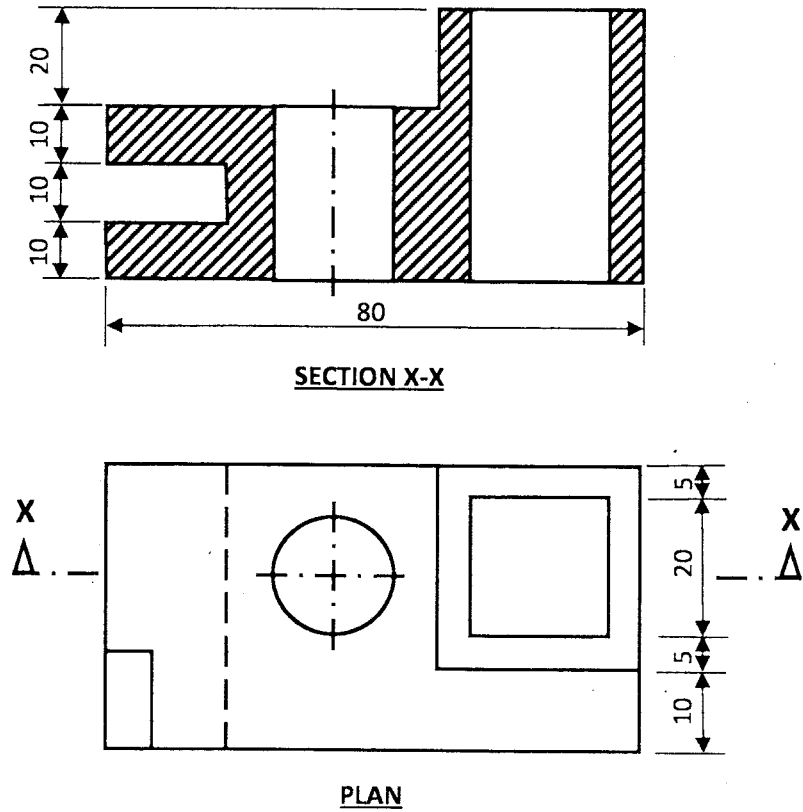

3.2.2 Woodwork Paper 2 (444/2)

As in the previous years, the council designed a suitable project for this level together with a comprehensive marking scheme. The subject teacher used the working drawings to supervise the fabrication of the project and the marking scheme to mark the candidates' projects. The marks were then sent to the council through the D.E.Os office.